

MODEL K2.S5500 PRODUCT OVERVIEW

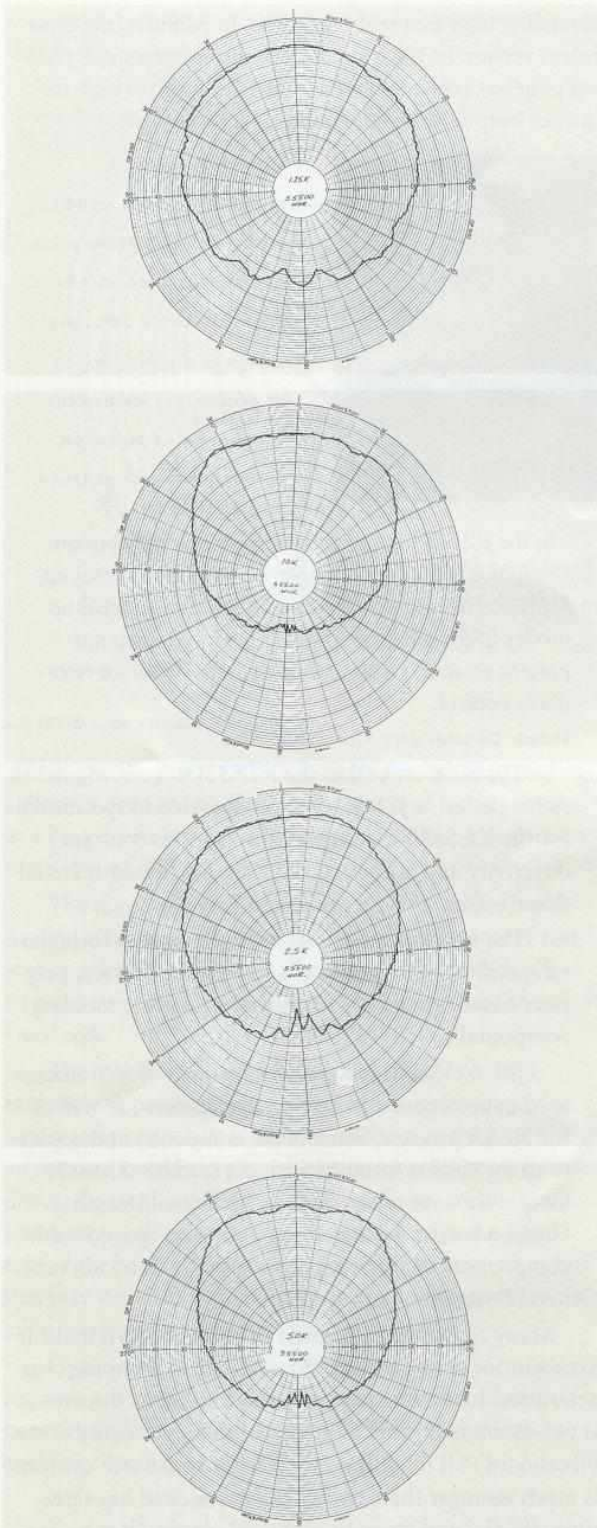

THE CONSTANT DIRECTIVITY OF THE HORN IN THE K2.S5500 RESULTS IN A VIRTUALLY UNIFORM RADIATION PATTERN, A FEAT THAT IS IMPOSSIBLE WITH DIRECT RADIATING DRIVERS

production of the new horn with its very tight tolerances and need for dimensional control.

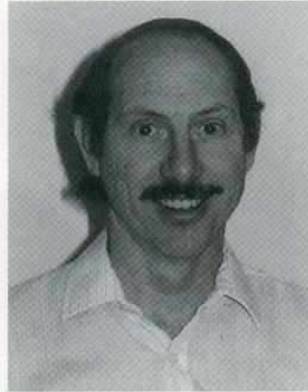

GREGORY TIMBERS IS JBL'S MANAGER OF SYSTEMS DEVELOPMENT. A GRADUATE OF THE SCHOOL OF ENGINEERING AT UCLA, MR. TIMBERS HAS BEEN IN JBL'S ENGINEERING DEPARTMENT FOR MORE THAN 20 YEARS. HE HAD OVERALL DESIGN RESPONSIBILITY FOR THE K2.S5500, DESIGNED ITS CONSTANT-DIRECTIVITY HORN, DEVELOPED IMAGINARY EQUIVALENT TUNING, AND INVENTED CHARGE-COUPLED NETWORK TECHNOLOGY.

CHARGE-COUPLED LINEAR DEFINITION™ DIVIDING NETWORK (PATENTS PENDING)

The K2.S5500 is the first production loudspeaker to utilize this latest JBL innovation. By doubling both the size and number of the capacitors in the dividing network, a voltage can be applied to the center point of the capacitor pairs. In so doing, the individual capacitors are charged, biasing the dielectric gap above or below ground potential without the D.C. voltage appearing outside of the confines of the capacitor pair. When this occurs, the music signals driving through the capacitors never cross the dielectric zero point, resulting in far more linear operating than without charge-coupling. This is analogous to the difference between a "Class A" amplifier and a "Class B" amplifier, for far more natural musical performance.

The source of the biasing voltage in the crossover network in the K2.S5500 is a nine-volt alkaline battery, which is housed under a removable access cover at the top of the network. Also under this cover are controls for the bi-amp and bi-wire operating modes. The battery life is approximately that of its shelf life—nominally four to five years for an alkaline battery—and is no more difficult to replace than the battery in a typical infrared remote control handset.

The benefits of the Charge-Coupled Linear Definition technology lie in the nature of what applying a charge does to the capacitors themselves. Crossover networks, of course, are composed of reactive and non-reactive components. The reactive components, coils and capacitors, are those components which are frequency-sensitive, that is,

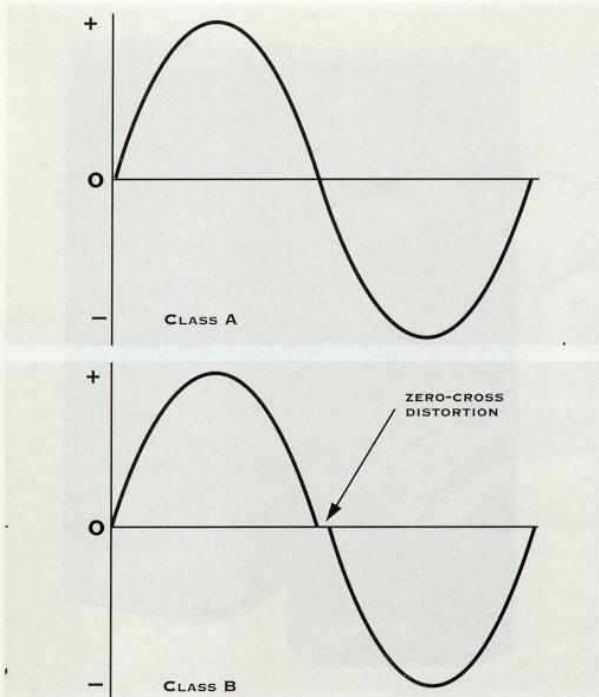

WITH CHARGE-COUPLED TECHNOLOGY, AUDIO SIGNALS DO NOT CROSS THE CAPACITORS' DIELECTRIC ZERO, SO THEY DO NOT EXPERIENCE THE PHASE ANOMOLIES OF CONVENTIONAL NETWORKS. THIS IS ANALOGOUS TO THE DIFFERENCE BETWEEN CLASS A AND CLASS B AMPLIFIER PERFORMANCE.

they selectively control the flow of audio frequency signals to the various drivers in the system by changing their resistance (actually, reactance) to various frequencies. Non-reactive components, generally resistors, printed circuit boards, and wire do not change their electrical nature with frequency. (The K2.S5500 is internally wired with Monster Cable® to assure completely non-reactive wire performance.)

Reactive components behave differently at different frequencies; this is the behavior that permits the dividing action of the crossover network. But along with this behavior comes varying transient characteristics, which also change with frequency. In the case of inductors, two factors which affect transient response are called core saturation and hysteresis. Core saturation results in a rapid change in inductance value resulting in F.M. distortion. Hysteresis is a characteristic which deals with inductance change in the area of zero crossings; this results in an increase in F.M. distortion, which is highly audible in audio reproduction.

Core saturation and hysteresis are relatively well understood and controllable in the design and selection of inductors. With capacitors, however, it is a different story. Capacitors are much more complex devices than coils, and their behavior in speaker crossover networks is far less understood.

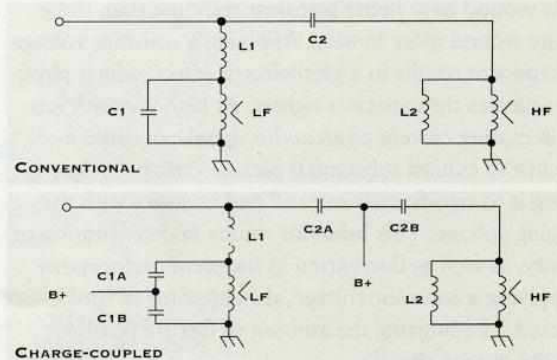

COMPARED TO CONVENTIONAL NETWORK DESIGN, CHARGE-COUPLED TECHNOLOGY USES TWICE AS MANY CAPACITORS AND THE VALUE OF EACH CAPACITOR IS DOUBLED. IN THIS WAY, THE CORRECT VALUE RESULTS AND THE VOLTAGE PRESENTED BY THE BATTERY IS TRANSPARENT TO THE AMPLIFIER.

Capacitors do not exhibit hysteresis, *per se*, but they have a behavior with similar results, called dielectric absorption. When an audio signal passing through a capacitor changes polarity, that is, it passes through zero volts, the current flow changes direction. But it does not do so immediately; due to dielectric absorption, the capacitor "remembers" its previous state and resists change. This leads to blurring of transients in the drive signal, a highly audible distortion.

A capacitor is fundamentally two conductive plates separated by a dielectric, or semi-insulator. Current flows through the capacitor by setting up different voltages on the two plates. The difference in the voltages and the frequency of the signal determine the amount of current flow. The impedance of a capacitor, that is, how much it resists the flow of current, is dependent on the signal frequency and the physical and electrical natures of the capacitor. In combination, these factors are called capacitive reactance.

Factors that determine the sound quality of a capacitor in a crossover network include the material composition of the conductive plates, the material composition of the dielectric, and the tightness of the winding of the capacitor. In general, "fast" capacitors, that is, those with technically high transient response, tend to sound sharp, while capacitors that sound "smooth" tend to have slow-

er transient response. Charge coupling combines the positive natures of capacitors which are both smooth and fast, and does so in basically two ways: 1) By controlling and utilizing a capacitor's piezoelectric nature and 2) by biasing the capacitor above zero crossing.

It has been established that capacitors that are more tightly wound have better transient response than those that are wound more loosely. Applying a constant voltage to a capacitor results in a piezoelectric effect, which physically squeezes the capacitor tighter. At high power levels, the alternating current of an audio signal can cause a capacitor to exhibit substantial piezoelectric behavior, causing it to significantly expand and contract with the changing voltage. This behavior results in deterioration of linearity, as well as fluctuation in transient performance. By applying a constant voltage, the capacitor is "pre-squeezed," minimizing the amount of flexure possible from the driving signal.

The second method charge coupling employs — biasing above zero crossing—probably has an even greater result than controlling piezoelectric effects. By biasing the capacitors so that the signal does not reverse current flow through the capacitor, zero crossing distortion is eliminated. Just as with Class A amplifiers, charge-coupled capacitors operate within their linear range, so time delay or dielectric absorption is neutralized, resulting in less phase distortion for more natural sound qualities.

ENERGY CONDUCTING BASE

Rather than the separate concrete base which is used in the K2.S9500, a laminated MDF base is constructed for the K2.S5500. Like the concrete base, this laminated MDF base is a massive energy sink. And, like the K2.S9500, the base is connected to the lower cabinet with stainless steel bolts. Rather than user-installed, however, the base is assembled to the cabinet at the JBL factory in Northridge, California, as it is necessary to employ the special equipment available only at the factory to precisely align the base to the cabinet which tunes the base for maximum energy transfer.

STYLING

Over the decades, many characteristics have set JBL speaker systems apart from the rest of the industry. Not only are exceedingly refined techniques and technology parts of the JBL heritage; JBL also is known for executing some of the most challenging and advanced driver and cabinet styling and integration in the audio world. Nowhere is this trait more in evidence than in JBL's Project



THE K2.S5500

Loudspeakers. Certainly the K2.S5500 is no exception. Extreme care and attention to detail grace the design and execution of the finish and cabinet, as well as the construction details and materials that go into the careful crafting of each of these incredible speaker systems. From the design of the casting that covers the bass driver's magnetic circuit to the gold plating on the logo on the front of the cabinet, the JBL tradition of innovation, craftsmanship and advanced design is clearly in evidence. At JBL, beautiful design is not merely something to be done. It is a way of life.

FINISH OPTIONS

The K2.S5500 is finished on all surfaces with several coats of gray polyester lacquer, applied and hand rubbed and detailed for a rich neutral finish. This gray background serves as visual platform for the trim panels which grace the front lower baffle and lower wing panels. The K2.S5500 is available with trim panels in four different finishes: high-gloss black piano-surface lacquer, satin lacquer over California walnut, satin lacquer over silver birds' eye maple burl, or satin lacquer over madrone burl. The two bass drivers are concealed behind a pair of beautifully contoured grilles covered in richly textured gray fabric. The grilles may be easily removed and reapplied.